

Entrance Mats **STRONG 25 MISTO SPAZZOLA**

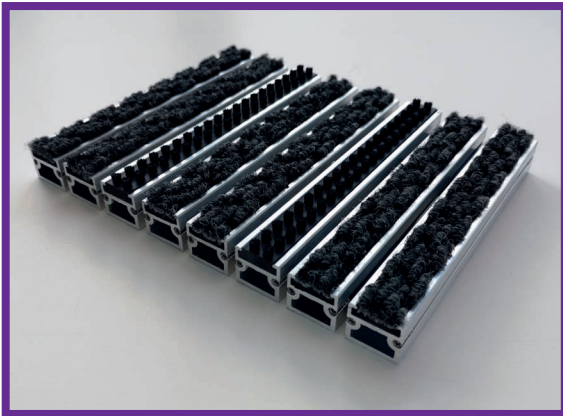

SUGGESTED LOCATION	<div style="display: flex; justify-content: space-around;"> <div style="border: 1px solid black; padding: 5px; text-align: center;"> INDOOR ✓ </div> <div style="border: 1px solid black; padding: 5px; text-align: center;"> COVERED OUTDOOR ✓ </div> <div style="border: 1px solid black; padding: 5px; text-align: center;"> OUTDOOR </div> </div>
CAPACITY	<div style="display: flex; justify-content: space-between;"> <div style="text-align: center;"> STATIC LOAD* ↓ up to 10000 kg </div> <div style="text-align: center;"> DYNAMIC LOAD* → up to 800 kg </div> </div> <div style="display: flex; justify-content: center; margin-top: 10px;"> </div>
STRENGTHS	<ul style="list-style-type: none"> • Strengthened profile for a higher load resistance • Combined cleaning of fine dirt and drying action

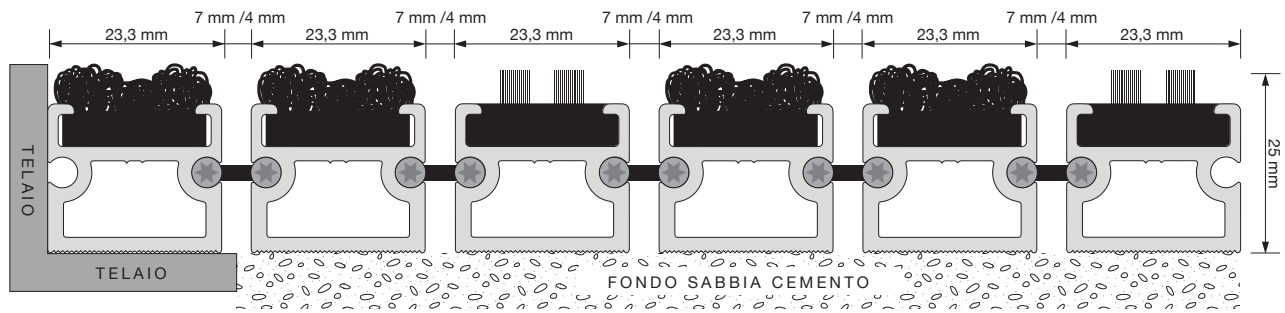

- Technical data refer to the proposed alternation (1 needle-punched Aran and 1 spazzola). Are available on request other combinations.

Structure in robust tubular aluminium wires joined by thermoplastic channels high-strengths buttonholes or closed. Space between the slats 7 or 4mm. Lining of rich technical needle punched already appearance and monofilament tufts of nylon combined in the favourite relation. Thickness 25mm. c.a.

Overall thickness	25 mm	Profile's material	Aluminium alloy EN AW-6060 from primary billet
Weight	19 kg/m ²	Profile's MAX lenght	300 cm - 200 cm for outdoor (also evaluable extraordinary lenghts)
Daily crossings	over 5000	MAX lenght walkway	300 cm (also evaluable extraordinary lenghts)
Distance between profiles	Standard 7 mm (optional 4 mm)	Covering	Needle-punched ARAN 100% PP UV 1500 gr/m ² Section PA monofilament tufts of nylon 0,3 mm punched on thermoplastic support
Ligation	Draining standard (optional closed)	Certifications	<ul style="list-style-type: none"> • Certificate of quality ISO 9001-2015
Profile's height	20 mm		
Middle section profile	2,2 mm		

N.B. Mat.en's technical mats are a system of modular and rollable mats, trailerable and heelguard realized on shape and design on project. Are provided compensation profiles to reach the exact dimensions requested where necessary. Are counted 5mm air on measures communicated to allow the laying, the removal and the cleaning of the mats.

*The static load refers to the capacity of the mat on an area of 100 cm² (10x10 cm), while the dynamic one to the weight of a transpallet who faces the mat transversely. The studies have been carried out in collaboration with the University of Brescia.

Entrance Mats **STRONG 25 MISTO SPAZZOLA**

Color range



A2



A4



A5



A10



A14



A25

Brush color



Black

ACCESSORIES

Containing frame in: aluminium, steel and brass

Anodized aluminium finishing-lists

Anodized aluminium antistumbling trailerable ramp

Stripes of needle punched for replacement

Special silicone for bonding stripes of needle punched

Connectors for entrance mats

Stainless steel containment tanks (optional draining)

Acoustic foam

SERVICES

Survey with measures tracking

Installation

Shaping

Sanitation of the product

Maintenance, cleaning and repairs

Coating replacement

Technical consultancy

Graphic draft realization for customized mats

Sampling

CUSTOMIZATIONS

BART (stainless steel bar with laser engraving logo)

Anodizing of aluminium profiles

RAL profiles painting

Special painting

CLEANING AND MAINTENANCE

To keep the carpets long-lived and working, we recommend to always check that the housing is levelled and in good condition and to ensure a thorough cleaning on a weekly basis.

- Aspire the top of the mat, roll it up and remove the dirt accumulated on the bottom with the help of a stiff bristle and vacuum cleaner (for draining channel).
- In case of stubborn dirt proceed after the ordinary cleaning with washing. Using a high pressure washer (at a minimum distance of 70cm), remove the accumulated dirt between the slats and on the coating. Allow the mat to dry completely, possibly vertically, before placing it back in its seat.
- To stain the textile coating, it's possible to clean the surface of the mat using warm water, laundry brush and the special soaking (can be purchased on www.mat-en.com).

In case the coating strips were irreversibly damaged (chewing gum, oil and cigarette burns) or in case of extreme wear you can contact the company for partial or total replacement.

It's possible to sanitize the mat with the appropriate specific products purchasable on www.mat-en.com.

CONSUMABLE

Mat.en offers a complete range of products designed for the maintenance, the cleaning and the sanitation of their products and the replacement of consumable accessories.

MATEN[®]
www.mat-en.com



Aderente ad AIB



Sistema di gestione qualità accreditato